

# UP2206

## 2.4GHz Power Amplifier IC

**Data Sheet**

**DS-2206-01**

The content of this technical document is subject to change without notice. Please contact UBEC for further information.

**Version: 0.7**  
**Released Date: 2009/6/11**

All rights are strictly reserved. Any portion of this document shall not be reproduced, copied, or transformed to any other forms without permission from Uniband Electronic Corp.

## UP2206

### 2.4GHz Power Amplifier IC

## 1. Product Description

---

The UP2206 is a high efficiency, linear power amplifier IC designed for 2.4GHz applications such as WLAN (802.11b/g), Bluetooth and other ISM-band applications. UP2206 is designed to provide excellent linearity and efficiency over a wide range of supply voltage and output power. The device is fabricated on an advanced GaAs/InGaP HBT process and packaged in a 3mmX3mm, 16pin, QFN with a bottom ground.

## 2. Features

---

- ❑ **Single 3.3V Supply (High Power)**
  - 27 dBm P1dB output power
  - 29 dB linear gain
  - 2.2% EVM at 18 dBm output power for 802.11g, 54 Mbps, OFDM
  - 130 mA at 18 dBm output power
  - 50 ohms internally matched input
- ❑ **Single 3.3V Supply (Low Current)**
  - 24.5 dBm P1dB output power
  - 28 dB linear gain
  - 2.4% EVM at 15 dBm output power for 802.11g, 54 Mbps, OFDM
  - 80 mA at 15 dBm output power
  - 50 ohms internally matched input

## 3. Typical Applications

---

- ❑ IEEE 802.11b
- ❑ General Purpose 2.4GHz ISM band applications

## 4. Pin Descriptions

Top View

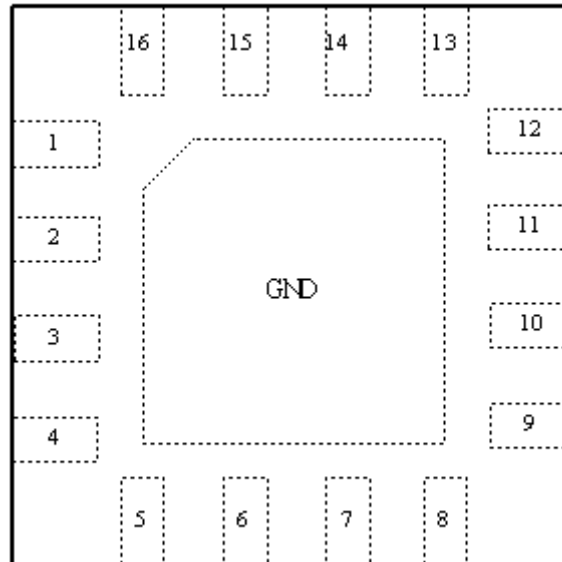

Pin #	Name	Description
1	RFin	RF input
3	Vcc1	Power supply for PA 1 <sup>st</sup> stage
4	Rb2	Bias control resistor
6	Vpc2	Power control for PA 2 <sup>nd</sup> stage
7	Vb2	Power supply for PA bias 2 <sup>nd</sup> stage
2, 5, 8, 9, 10, 12, 13	NC	NC
11	Vcc2+RFout	Power supply for PA and RF out
14	Vdet	Output power detection
15	Vb1	power supply for PA bias 1 <sup>st</sup> stage
16	Vpc1	Power control for PA 1 <sup>st</sup> stage

## 5. Package Specification

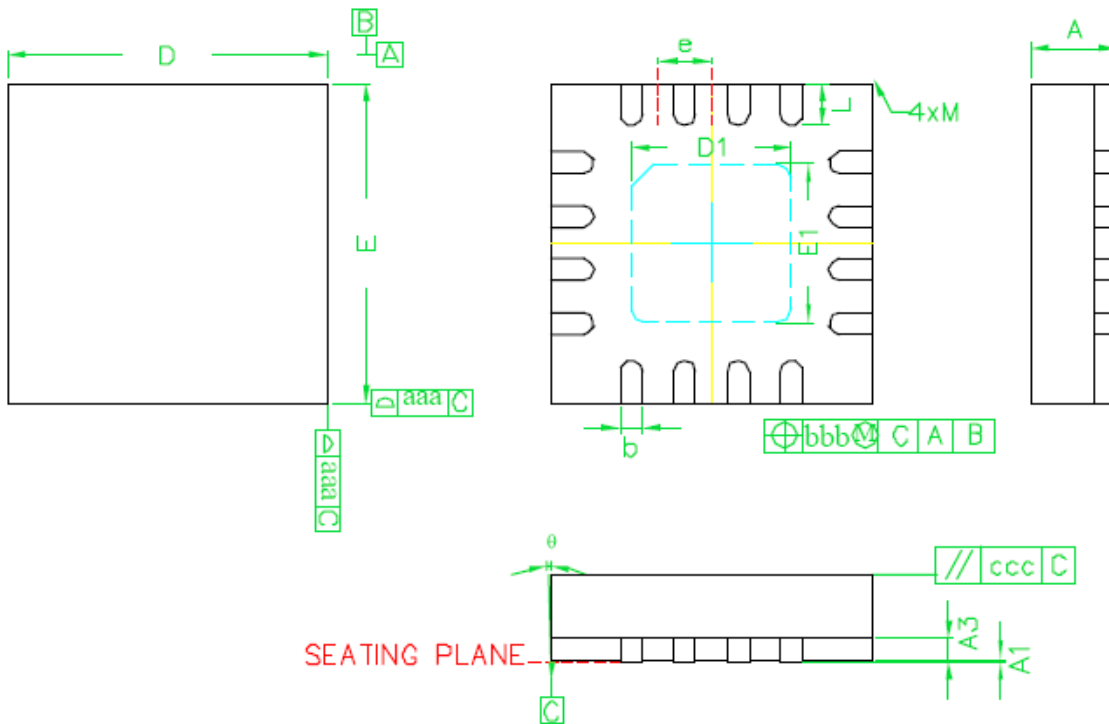

Symbols	Dimensions In Millimeters		
	Min.	Nom.	Max.
A	0.80	0.9.	1.00
A1	0	0.015	0.030
A3	-----	0.20 REF.	-----
b	0.18	0.23	0.30
D	2.85	3.00BSC	3.15
D1	-----	1.48BSC	-----
E	2.85	3.00BSC	3.15
E1	-----	1.48BSC	-----
e	-----	0.50BSC	-----
L	0.30	0.40	0.50
$\theta$	-12	-----	0
aaa	-----	0.25	-----
bbb	-----	0.10	-----
ccc	-----	0.10	-----
M	-----	-----	0.05
Burr	0	0.030	0.060

## 6. Absolute Maximum Ratings

Parameter	Value	Unit
Supply voltage	3.6	V
Power control voltage	3.5	V
RF input power	-8	dBm
Operating case temperature	-30 to 80	°C
Storage temperature	-30 to 120	°C

## 7. Electrical Characteristics

### 7.1. Single 3.3 V Supply (High Power)

\* Vcc, Vpc1, Vpc2, Vb1, Vb2 are all connected to 3.3 V. Refer to Application Circuit Figure 9-1.

Parameter	Conditions	Min.	Typ.	Max.	Unit
Operating Power Supply Voltage		3.0	3.3	3.6	V
Frequency Range		2.4	2.45	2.5	GHz
Quiescent Current		75	95	115	mA
Current Consumption	Pout =18 dBm; EVM≤2.2%	---	130	---	mA
Linear Gain		27	29	31	dB
Pout at 1dB Gain Compression		25	27	---	dBm
Input Return Loss		10	13	---	dB
Sensitivity of Power Detector		---	0.038	---	V/dBm
Power Control - Enable		3.0	3.3	---	V
Power Control - Disable		---	---	0.5	V
Power Down Current	V <sub>PC</sub> =0V	---	40	80	uA
Output Harmonics		---	-40	---	dBc

## 7.2. Single 3.3 V Supply (Low Current)

\*Vcc, Vpc1, Vpc2, Vb1, Vb2 are all connected to 3.3 V. Refer to Application Circuit Figure 9-2

Parameter	Conditions	Min.	Typ.	Max.	Unit
Operating Power Supply Voltage		3.0	3.3	3.6	V
Frequency Range		2.4	2.45	2.5	GHz
Quiescent Current		55	60	65	mA
Current consumption	Pout=15dBm; EVM≤2.4%	---	80	---	mA
Linear Gain		27	28	29	dB
Pout at 1dB Gain Compression		24	24.5	---	dBm
Input Return Loss		10	12	---	dB
Sensitivity of Power Detector		---	0.047	---	V/dB
Power Control - Enable		3.0	3.3	---	V
Power Control - Disable		---	---	0.5	V
Power Control Current		---	---	3.5	mA
Power Down Current		---	---	4	uA



Caution: ESD sensitive.

## 8. Performance Data

### 8.1. Single 3.3 V Supply (High Power)

\*  $V_{cc}$ ,  $V_{pc1}$ ,  $V_{pc2}$ ,  $V_{b1}$ ,  $V_{b2}$  are all connected to 3.3 V,  $T=25^{\circ}\text{C}$ .

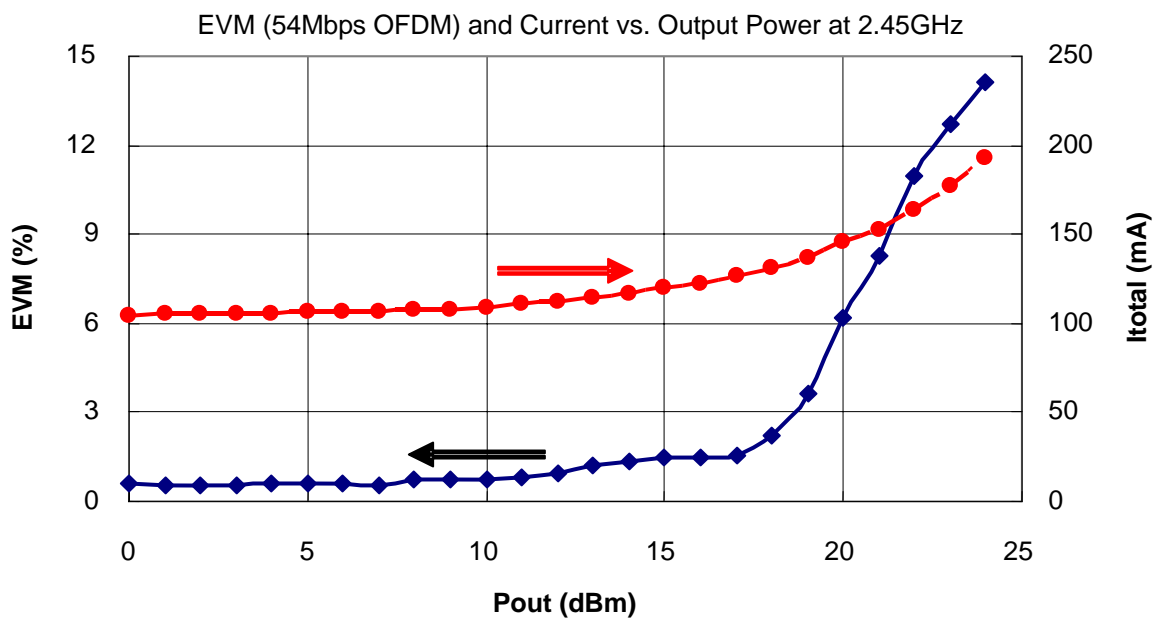
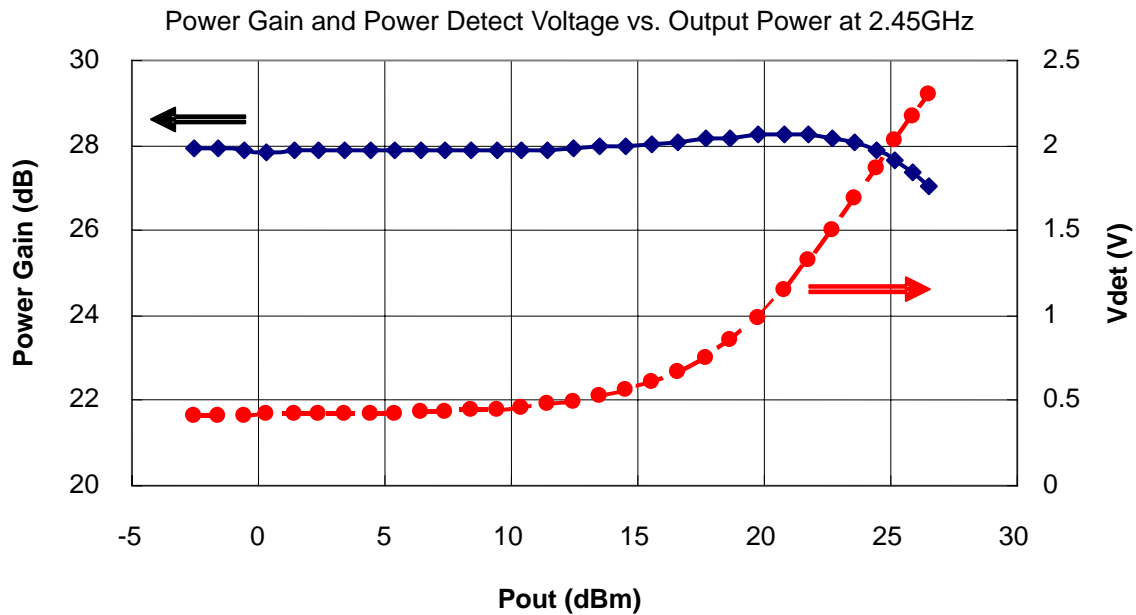

EVM (54Mbps OFDM) and Output Power vs. Vpc1/Vpc2 at 2.45GHz

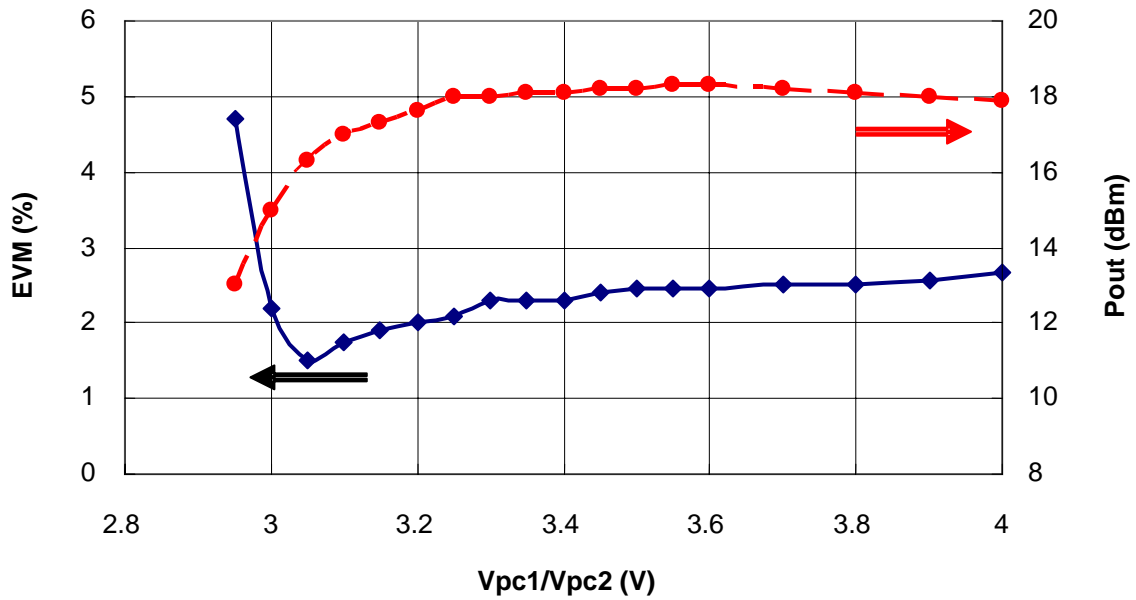

Current and Output Power vs. Vpc1/Vpc2 at 2.45GHz

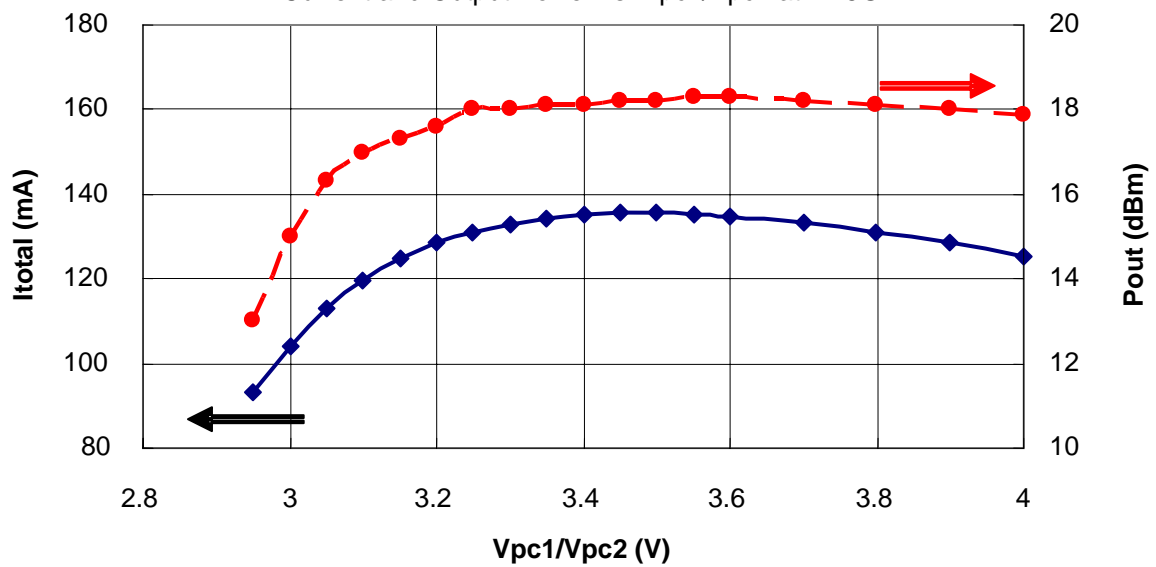



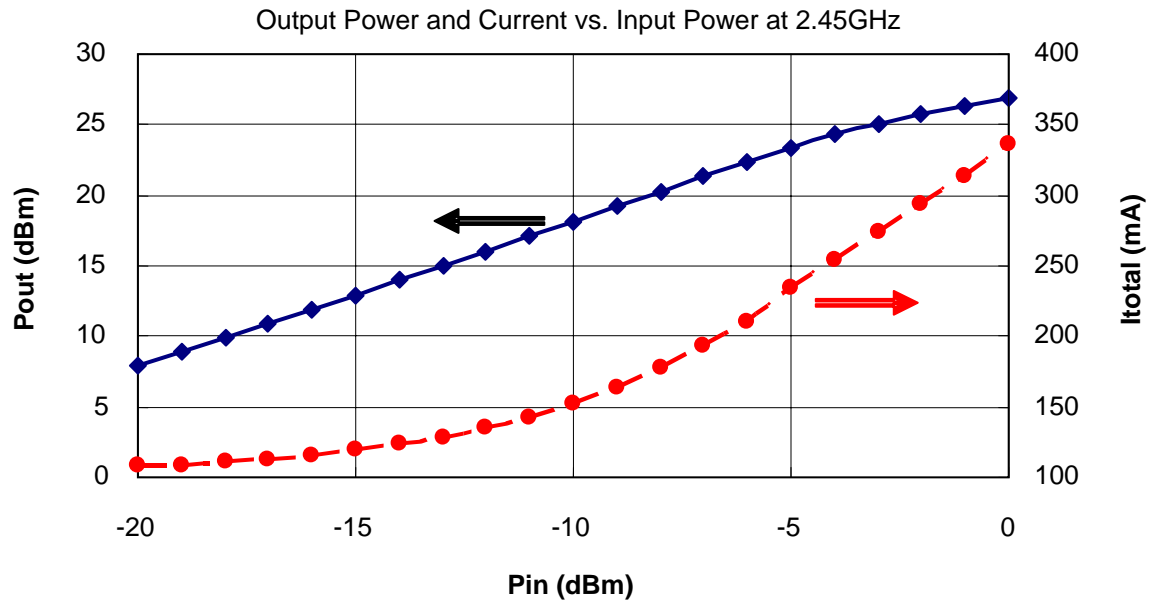

## 8.2. Single 3.3 V Supply (Low Current)

\* Vcc, Vpc1, Vpc2, Vb1, Vb2 are all connected to 3.3 V, T=25°C.

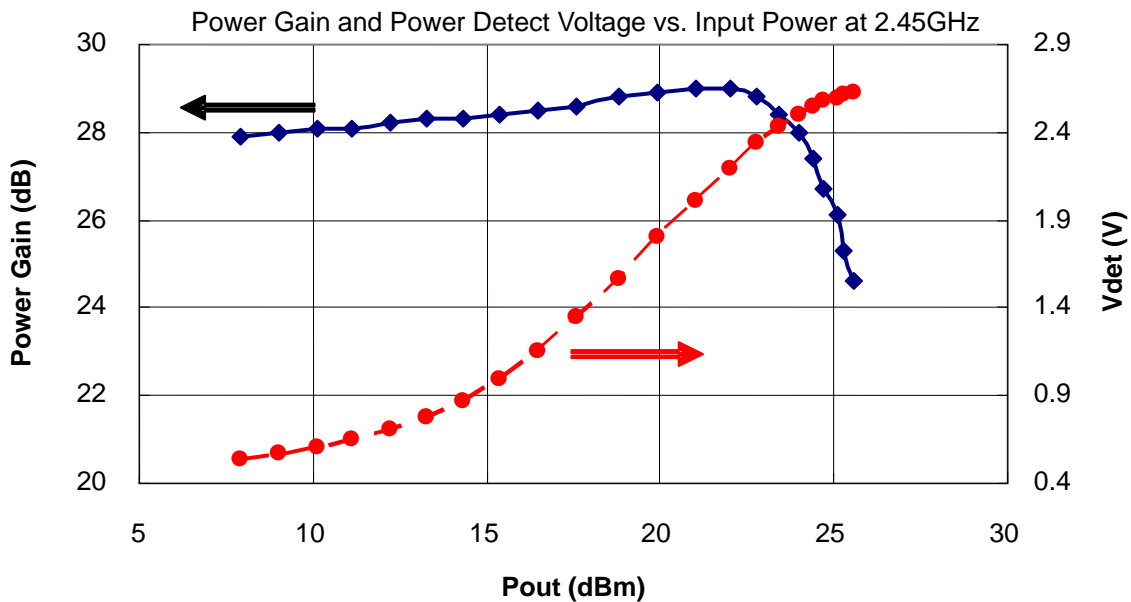
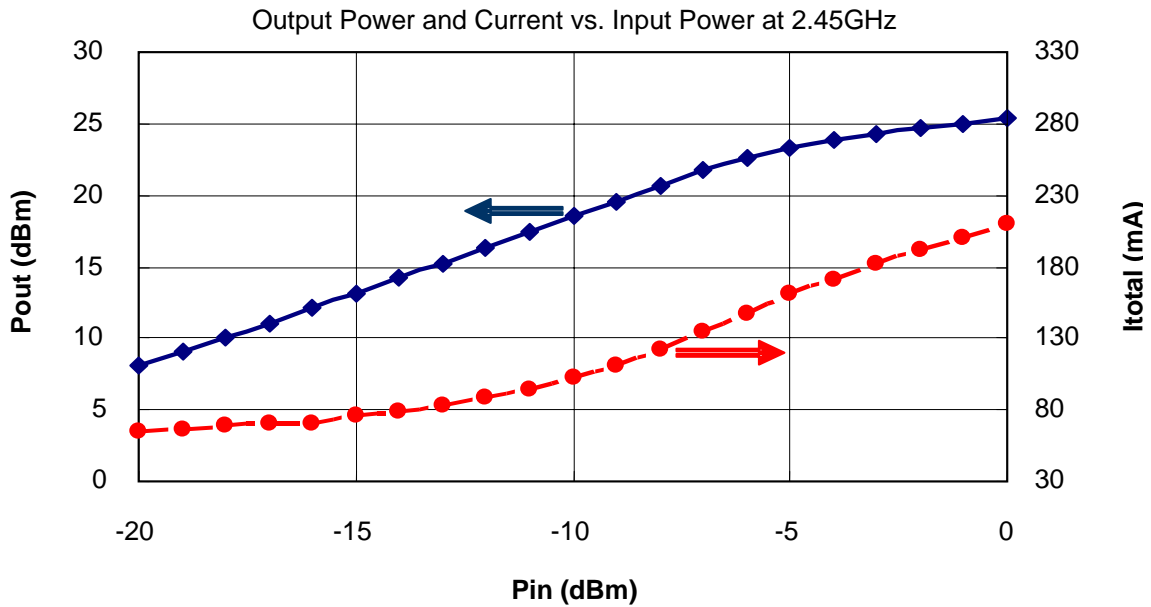

EVM (54Mbps OFDM) and Current vs. Output Power at 2.45GHz

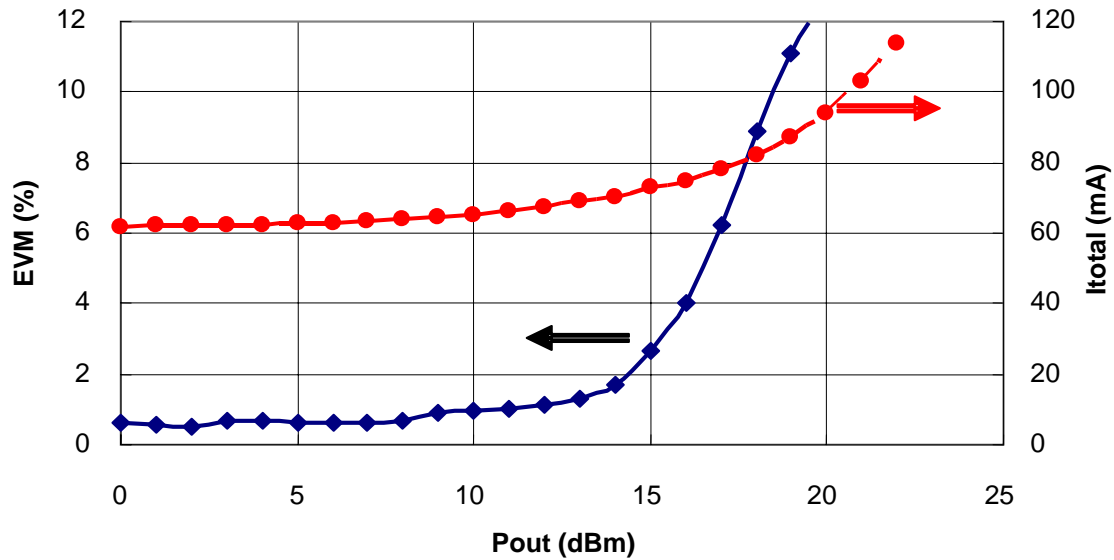

EVM (54Mbps OFDM) and Output Power vs. Vpc1/Vpc2 at 2.45GHz

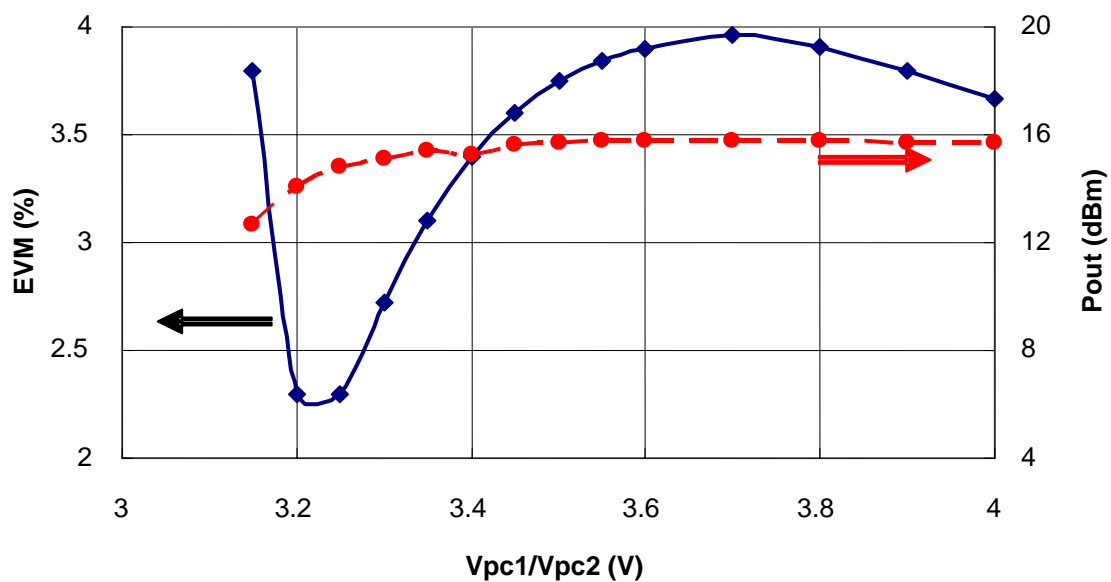

Current and Output Power vs. Vpc1/Vpc2 at 2.45GHz

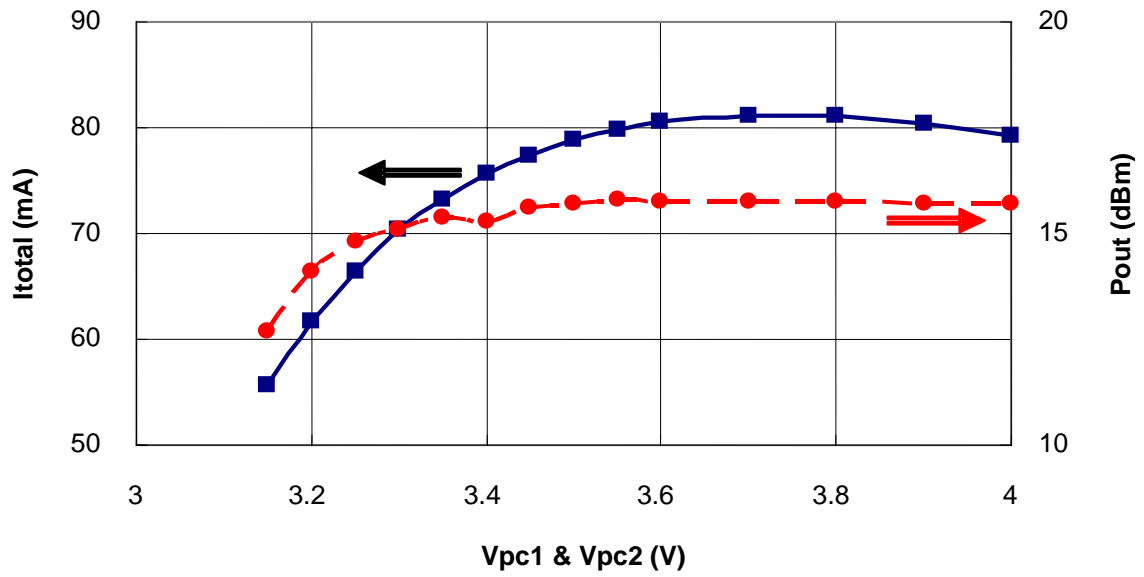

## 9. Typical Application Circuit

### 9.1. Single 3.3 V Supply (High Power)

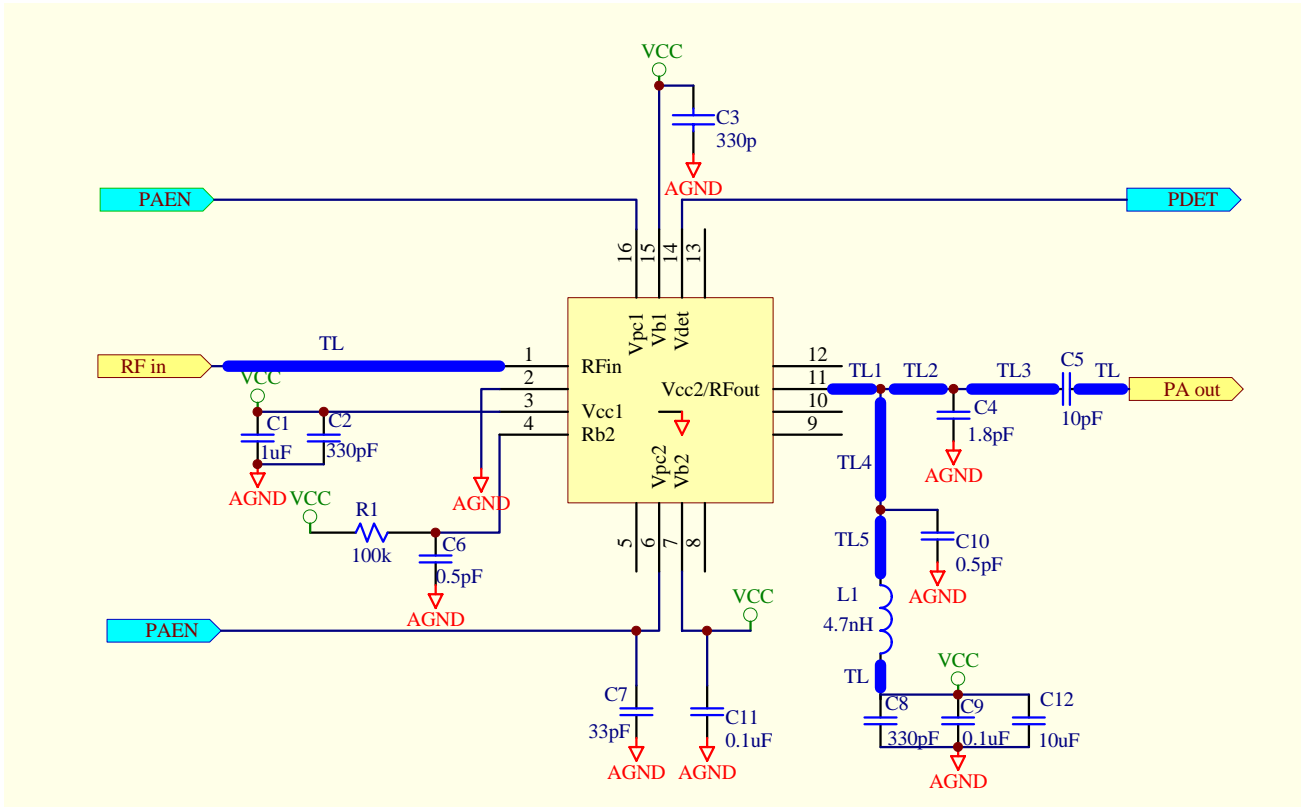

Figure 9-1. Application Circuit of High Power/ High Efficiency Power Amplifier

All TL are 50 ohm lines

	TL1	TL2	TL3	TL4	TL5
Length (mil)	<8	<22	24~80	<8	24~40

Note1: TL1, TL2, TL4 as short as possible (by the meaning of much closed to PA).

Note2: All length measured are from edge to edge.

9.2. Single 3.3 V supply (Low Current)

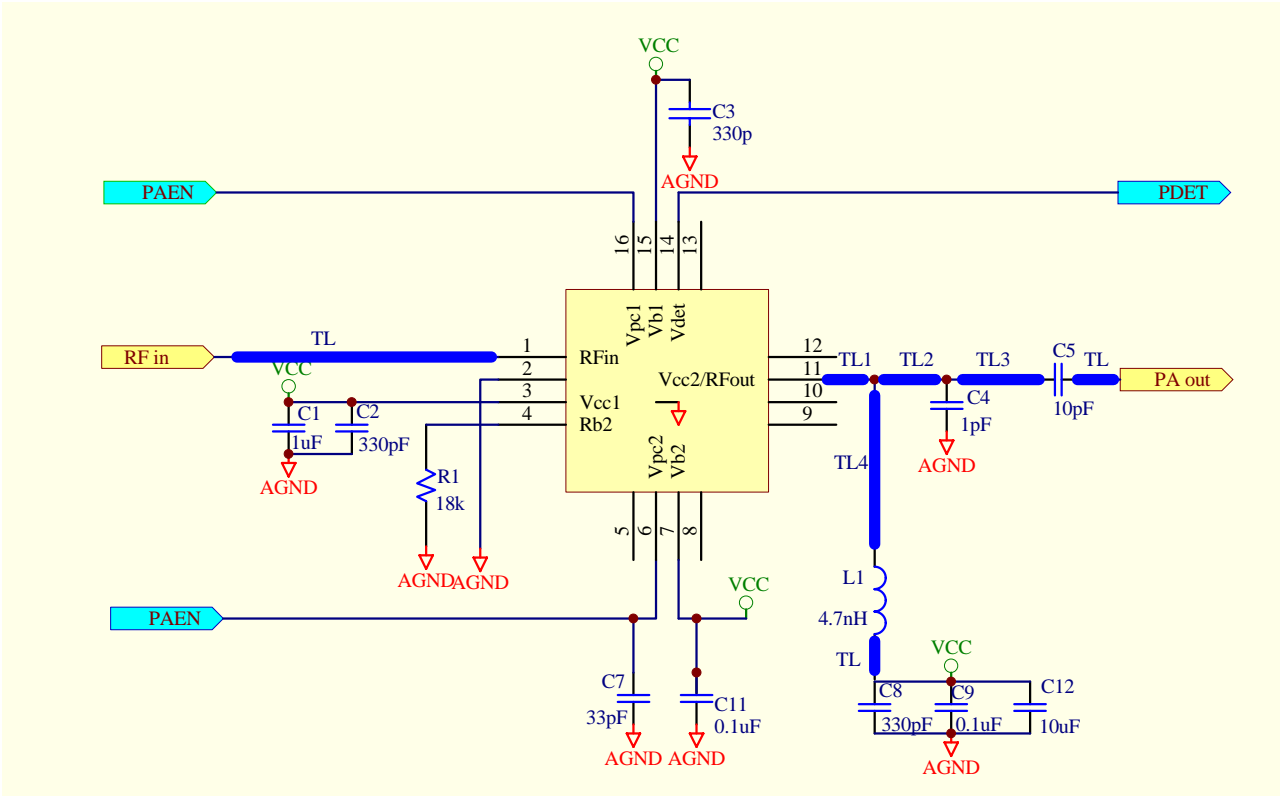

Figure 9-2. Application Circuit of Low Current / High Efficiency Power Amplifier

All TL are 50 ohm lines

	TL1	TL2	TL3	TL4
Length (mil)	<8	32	24~80	24~40

## Revision History

Revision	Date	Description of Change
0.0	2003/7/1	Original.
0.1	2003/7/3	1. Add dimension specification of QFN package 2. Modify the table of key electrical characteristics and typical application
0.2	2004/5/14	1. Change the PIN placement 2. Modify the table of chip performance
0.3	2004/8/31	Add detail performance data .
0.4	2005/1/13	Circuit modification.
0.5	2005/4/21	Update Vcc 5V data and 3.3 V low current data.
0.6	2006/ 6/ 23	Include WDCT application circuit.
0.7	2009/6/11	1. Update to new format 2. Remove Vcc 5V Data and WDCT application circuit.

## Contact UBEC:

### *Headquarters*

Address: 6F-1, No. 192, Dongguang Rd., Hsinchu, 300 Taiwan

Tel: +886-3-5729898

Fax: +886-3-5718599

Website: <http://www.ubec.com.tw>

### *Sales Services*

Tel: +886-3-5729898

Fax: +886-3-5718599

E-mail: [sales@ubec.com.tw](mailto:sales@ubec.com.tw)

### *FAE Services*

Tel: +886-3-5729898

Fax: +886-3-5718599

E-mail: [fae@ubec.com.tw](mailto:fae@ubec.com.tw)

## DISCLAIMER

TO THE BEST KNOWLEDGE OF THE UNIBAND ELECTRONIC CORPORATION (UBEC), THIS DOCUMENT IS ADEQUATE FOR ITS INTENDED PURPOSES. UBEC MAKES NO WARRANTY OF ANY KIND WITH REGARD TO ITS COMPLETENESS AND ACCURACY. UBEC EXPRESSLY DISCLAIMS ANY AND ALL OTHER WARRANTIES, WHETHER EXPRESSED, IMPLIED, OR STATUTORY INCLUDING WITHOUT LIMITATION WARRANTIES OF TITLE, MERCHANTABILITY, NON-INFRINGEMENT, AND FITNESS FOR A PARTICULAR PURPOSE, WHETHER ARISING IN LAW, CUSTOM, CONDUCT, OR OTHERWISE.