

# UA2716E

## Broadband Amplifier MMICs

### Data Sheet

### DS-2716-02

The content of this technical document is subject to change without notice. Please contact UBEC for further information.

**Version: 1.0**  
**Released Date: 2007/1/5**

All rights are strictly reserved. Any portion of this paper shall not be reproduced, copied, or transformed to any other forms without prior permission from Uniband Electronic Corp.

**UA2716E**

Broadband Amplifier MMICs

## 1. Product Description

---

The UA2716E general purpose wideband amplifier and low current IC with internal input/output matching and ESD diodes inside is packaged in a 6-pin SOT363 plastic package.

## 2. Features

---

- Single 5V power supply
- Internally matched to 50Ω
- Very wide frequency over DC to 4.6 GHz
- Over 23 dB linear gain at 2.2 GHz
- High frequency gain peaking for cable loss compensation
- Unconditionally stable
- P1dB over 5 dBm at 2.2 GHz
- Low supply current about 17 mA

## 3. Typical Applications

---

- General Purpose
- DBS
- LNB IF Amplifier
- DVB
- Cable
- ISM

## 4. Pin Configuration

**Table 1 Pin Descriptions**

Pin #	Description
1	Vcc
2, 5	GND1
3	RF out
4	GND2
6	RF in

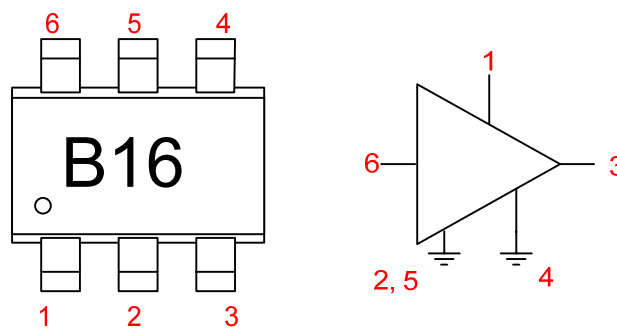

**Figure 1. Simplified Outline (SOT363) and Symbol.**

## 5. Application Circuit

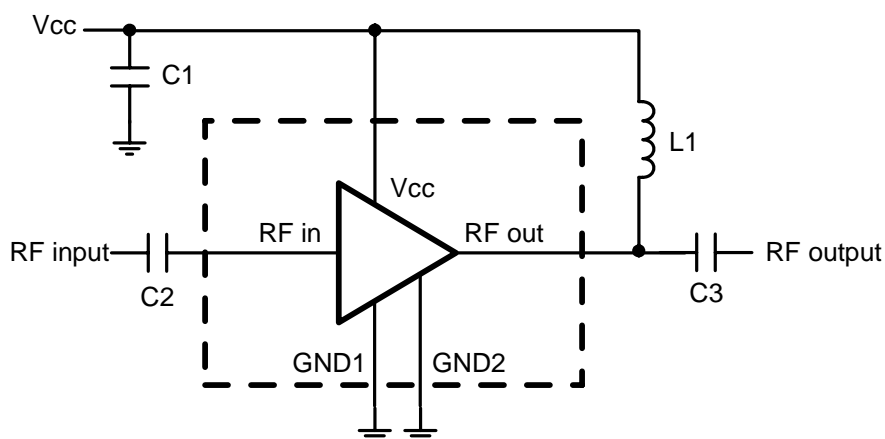

$C1=1\text{nF}$ ,  $C2=100\text{pF}$ ,  $C3=100\text{pF}$ . The nominal value of the RF choke,  $L1$  is 33 nH. Increasing the inductor value will shift the curve towards the lower frequency region. The operating frequency can be lowered to 50MHz when  $L1$  is larger than 220nH.

**Figure 2. Application Circuit**

## 6. Operating Condition

**Table 2. Absolute Maximum Ratings**

Symbol	Parameters	Conditions	Typ.	Max.	Unit
V <sub>cc</sub>	DC Supply Voltage	RF input AC coupled	-	8	V
I <sub>cc</sub>	Supply Current		-	25	mA
P <sub>tot</sub>	Total Power Dissipation	T <sub>a</sub> ≤ 90 °C	-	200	mW
T <sub>st</sub>	Storage Temperature		-65	150	°C
T <sub>j</sub>	Operating Junction Temperature		-40	150	°C
P <sub>D</sub>	Maximum Drive Power		-	-5	dBm

**Table 3. Thermal Characteristics**

Symbol	Parameters	Conditions	Value	Unit
R <sub>th</sub>	Thermal Resistance from Junction to Solder Point	P <sub>tot</sub> = 80 mW; T <sub>a</sub> ≤ 90 °C	300	K/W

## 7. Electrical Characteristics

**Table 4. Electrical Characteristics**

V<sub>cc</sub> = 5 V; I<sub>cc</sub> = 17 mA; T<sub>a</sub> = 25 °C; unless otherwise specified.

Symbol	Parameters	Conditions	Min.	Typ.	Max.	Unit
V <sub>cc</sub>	Supply Voltage		-	5	-	Volt.
I <sub>cc</sub>	Supply Current		-	17	-	mA
S <sub>21</sub>   <sup>2</sup>	Insertion Power Gain	f = 100 MHz	-	18.5	-	dB
		f = 0.9 GHz	-	23	-	dB
		f = 1.8 GHz	-	23	-	dB
		f = 2.2 GHz	-	23	-	dB
		f = 2.5 GHz	-	23	-	dB
S <sub>11</sub>   <sup>2</sup>	Input Return Loss	f = 0.9 GHz	10	-	-	dB
		f = 2.2 GHz	10	-	-	dB
S <sub>22</sub>   <sup>2</sup>	Output Return Loss	f = 0.9 GHz	10	-	-	dB
		f = 2.2 GHz	10	-	-	dB
S <sub>12</sub>   <sup>2</sup>	Isolation	f = 0.9 GHz	-	31	-	dB
		f = 2.2 GHz	-	32.5	-	dB
NF	Noise Figure	f = 0.9 GHz	-	3.8	-	dB
		f = 2.2 GHz	-	4.3	-	dB
BW	Bandwidth	at  S <sub>21</sub>   <sup>2</sup> -3 dB below flat gain at 0.9 GHz	-	4.6	-	GHz
K	Stability Factor	f = 0.9 GHz	-	1.2	-	-
		f = 2.2 GHz	-	1.3	-	-
P <sub>L(sat)</sub>	Saturated Load Power	f = 0.9 GHz	-	11.5	-	dBm
		f = 2.2 GHz	-	10.5	-	dBm
P <sub>L,1 dB</sub>	Load Power	at 1 dB gain compression; f = 0.9 GHz	6	7.5	-	dBm
		at 1 dB gain compression; f = 2.2 GHz	5	5	-	dBm



**Caution: ESD sensitive.**

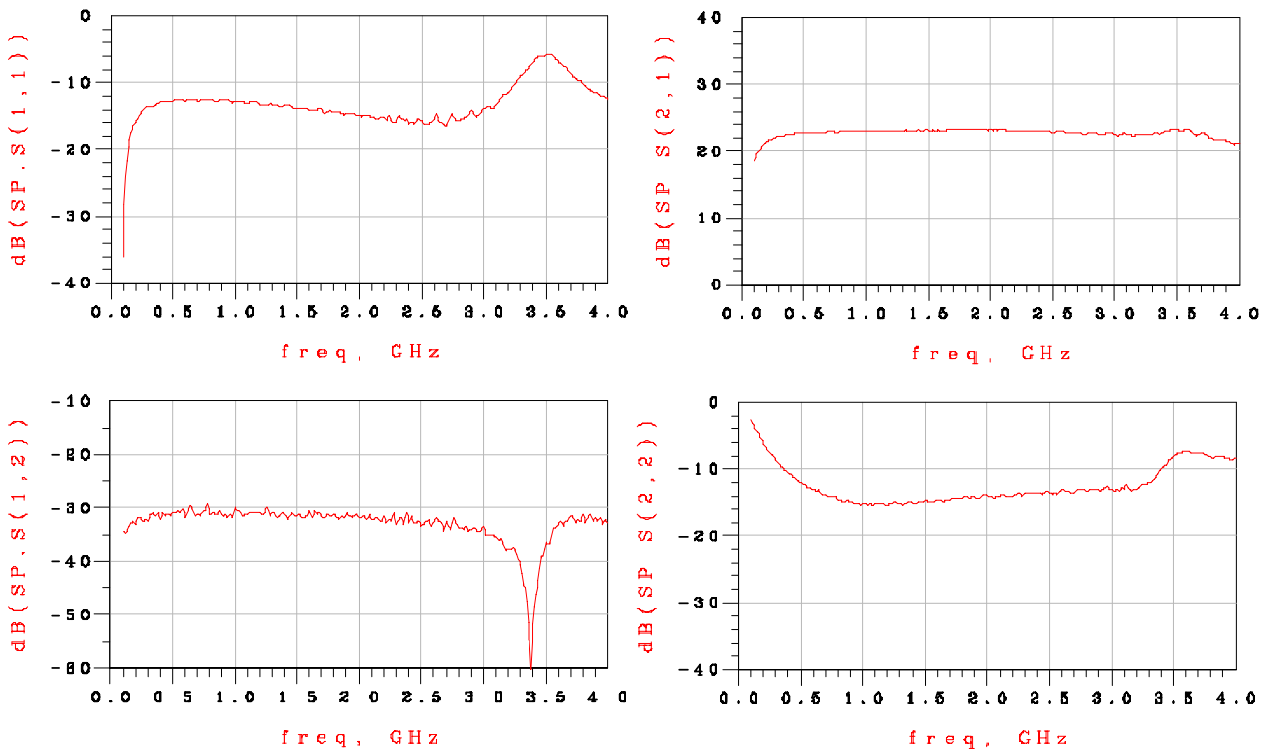

**Figure 3. S-parameter ( $V_{cc} = 5\text{ V}$ ,  $I_{cc} = 17\text{ mA}$ ,  $P_{in} = -40\text{ dBm}$ ,  $Z_0 = 50\ \Omega$ )**

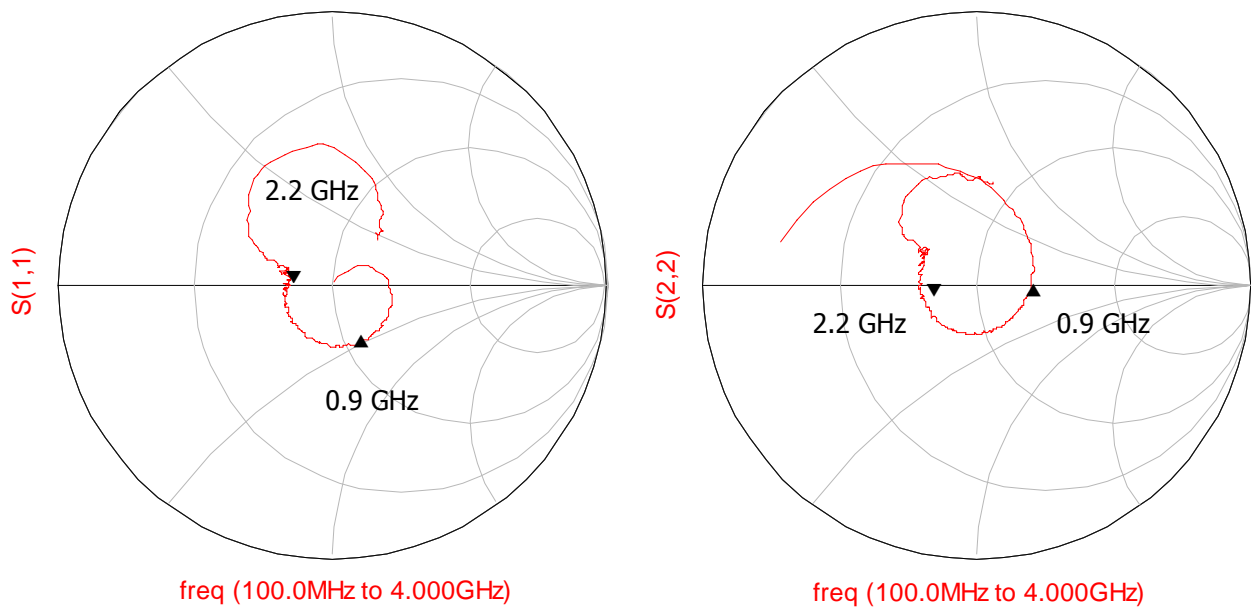

**Figure 4.  $S_{11}$  &  $S_{22}$  ( $V_{cc} = 5\text{ V}$ ,  $I_{cc} = 17\text{ mA}$ ,  $P_{in} = -40\text{ dBm}$ ,  $Z_0 = 50\ \Omega$ )**

## 8. Package Drawing

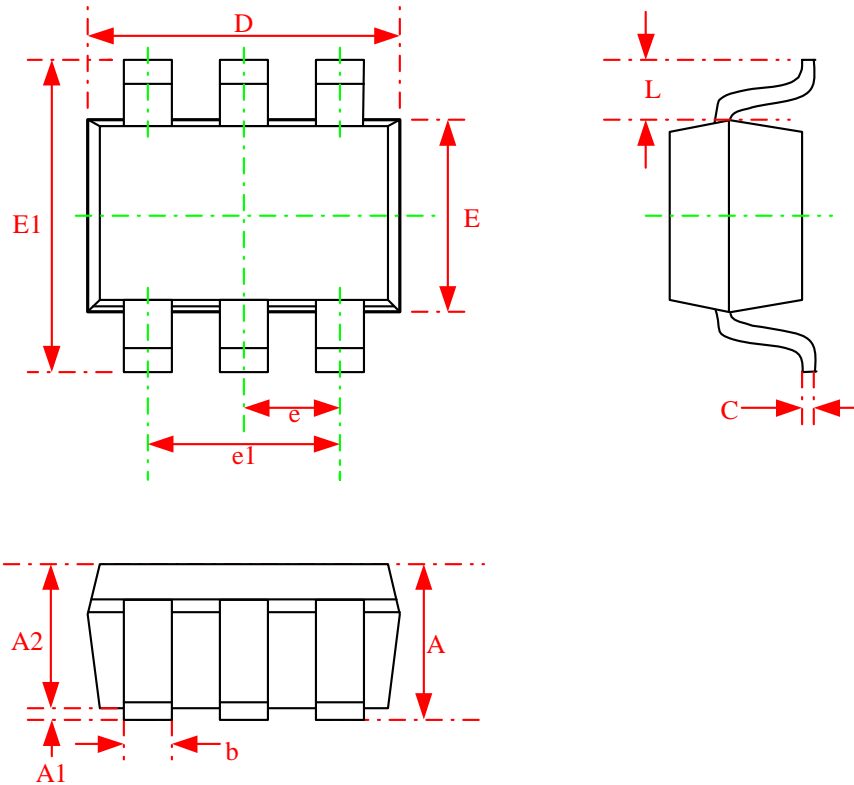

Figure 5. Package Outline

Table 5. Dimension Description

Symbol	Millimeters		Inches	
	Min.	Max.	Min.	Max.
A	0.90	1.10	.038	.044
A1	0.025	0.10	.001	.004
A2	0.875	1.00	.035	.040
b	0.20	0.40	.008	.016
C	0.10	0.15	.004	.006
D	1.90	2.10	.076	.084
E	1.15	1.35	.046	.054
E1	2.00	2.20	.080	.088
e	0.65 BSC.		.026 BSC.	
e1	1.30 BSC.		.052 BSC.	
L	0.425 REF.		.017 BSC.	

## Revision History

Revision	Date	Description of Change
1.0	2007/01/05	Original

## Contact UBEC:

### *Headquarters*

Address: 6F-1, No. 192, Dongguang Rd., Hsinchu, 300 Taiwan

Tel: +886-3-5729898

Fax: +886-3-5718599

Website: <http://www.ubec.com.tw>

### *Sales Services*

Tel: +886-3-5729898

Fax: +886-3-5718599

E-mail: [sales@ubec.com.tw](mailto:sales@ubec.com.tw)

### *FAE Services*

Tel: +886-3-5729898

Fax: +886-3-5718599

E-mail: [fae@ubec.com.tw](mailto:fae@ubec.com.tw)

## DISCLAIMER

TO THE BEST KNOWLEDGE OF THE UNIBAND ELECTRONIC CORPORATION (UBEC), THIS DOCUMENT IS ADEQUATE FOR ITS INTENDED PURPOSES. UBEC MAKES NO WARRANTY OF ANY KIND WITH REGARD TO ITS COMPLETENESS AND ACCURACY. UBEC EXPRESSLY DISCLAIMS ANY AND ALL OTHER WARRANTIES, WHETHER EXPRESSED, IMPLIED, OR STATUTORY INCLUDING WITHOUT LIMITATION WARRANTIES OF TITLE, MERCHANTABILITY, NON-INFRINGEMENT, AND FITNESS FOR A PARTICULAR PURPOSE, WHETHER ARISING IN LAW, CUSTOM, CONDUCT, OR OTHERWISE.